

IF IT'S NOT ON THE LIST, IT'S COVERED! (It even includes rental up to 6 days.)

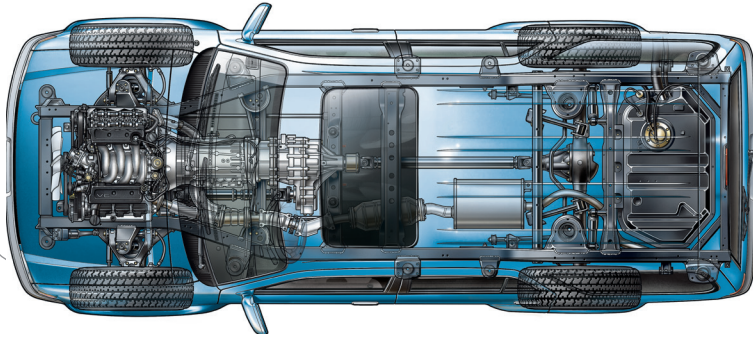

It's like new car coverage for a pre-owned vehicle.

Drive with confidence, coast-to-coast, knowing that your vehicle is covered by one of the most comprehensive aftermarket protection plans available anywhere. And in the unlikely event that there is a problem, you can count on the same award-winning service that has made Preferred Warranties one of the fastest growing Extended Service Contract providers in the U.S.

- **24/7 Emergency Road Service** everywhere in the continental United States
- **Award-winning customer service**, with phones manned 24/7
- **Outstanding record of customer & dealer satisfaction** since 1992
- **ASE-certified claims adjusters**
- **Approved claims paid fast!** (5 days or less after the work is completed.)
- **Only select dealerships** that are known for quality, dependable pre-owned vehicles are approved to offer Preferred Warranties plans

Premier covers everything in all of our other plans – and more. In fact, it's so comprehensive that this “exclusionary” contract lists only the things not covered. In other words, if it's not listed on the contract, IT IS COVERED!

Your Premier Plan covers practically all factory-installed mechanical and electrical operating parts. The few items not covered are mostly those involved in scheduled services and normal wear and tear, such as:

- Regular maintenance services as recommended by the manufacturer
- Normal maintenance parts and services such as engine tune-ups, batteries, filters, fluids, A/C refrigerant, hoses and belts, wiper blades, brake pads, tires, wheels and balancing, exhaust system, catalytic converter, and manual clutch components
- Window glass, head lamps, trim, moldings, upholstery, convertible tops, paint, sheet metal & flexible body parts, bumpers, door panels & handles, structural framework
- Aftermarket accessories or equipment not installed by the manufacturer
- Repairs to meet emissions standards
- Hybrid vehicle battery

Listed items are general guidelines only. Please see contract for complete details. A form of contract can be obtained by contacting your dealer or a PWI representative.

DRIVE WITH CONFIDENCE, COAST-TO-COAST.™